

Product datasheet

Specifications



variable speed drive ATV310, 4 kW/
5hp normal duty, 3 kW/4hp heavy
duty, 380...460 V, 3 phases, without
EMC filter

ATV310HU30N4A

! Discontinued

Main

Range of product	Easy Altivar 310
Product or component type	Variable speed drive
Product specific application	Simple machine
Assembly style	With heat sink
Device short name	ATV310
Network number of phases	Three phase
[Us] rated supply voltage	380...460 V - 15...10 %
Motor power kW	4 kW for normal duty 3 kW for heavy duty
Motor power hp	5 hp for normal duty 4 hp for heavy duty
Noise level	50 dB

Complementary

Product destination	Asynchronous motors
Quantity per set	Set of 1
EMC filter	Without EMC filter
type of cooling	Integrated fan
Supply frequency	50/60 Hz +/- 5 %
Communication port protocol	Modbus
Connector type	RJ45 (on front face) for Modbus
Physical interface	2-wire RS 485 for Modbus
Transmission frame	RTU for Modbus
Transmission rate	4800 bit/s 9600 bit/s 19200 bit/s 38400 bit/s
Number of addresses	1...247 for Modbus
Communication service	Read holding registers (03) 29 words Write single register (06) 29 words Write multiple registers (16) 27 words Read/write multiple registers (23) 4/4 words Read device identification (43)

Line current	14.2 A at 380 V (normal duty) 11.1 A at 380 V (heavy duty) 11.6 A at 460 V (normal duty) 9.2 A at 460 V (heavy duty)
Apparent power	9.3 kVA at 460 V (normal duty) 7.3 kVA at 460 V (heavy duty)
Prospective line I_{sc}	5 kA
Continuous output current	8.9 A normal duty 7.1 A heavy duty
Maximum transient current	9.8 A during 60 s (normal duty) 10.7 A during 60 s (heavy duty)
Power dissipation in W	94.0 W, at I _n (normal duty) 80.2 W, at I _n (heavy duty)
Speed drive output frequency	0.5...400 Hz
Nominal switching frequency	4 kHz
Switching frequency	2...12 kHz adjustable
Speed range	1...20
Transient overtorque	170...200 % of nominal motor torque depending on drive rating and type of motor
Braking torque	Up to 150 % of nominal motor torque with braking resistor at high inertia Up to 70 % of nominal motor torque without braking resistor
Asynchronous motor control profile	Energy saving ratio Sensorless flux vector control Quadratic voltage/frequency ratio
Motor slip compensation	Adjustable Preset in factory
Output voltage	380...460 V three phase
Electrical connection	Terminal, clamping capacity: 1.5...4 mm ² (L1, L2, L3, PA+, PB, U, V, W)
Tightening torque	1.2...1.4 N.m
Insulation	Electrical between power and control
Supply	Internal supply for reference potentiometer: 5 V (4.75...5.25 V)DC, <10 mA with overload and short-circuit protection Internal supply for logic inputs: 24 V (20.4...28.8 V)DC, <100 mA with overload and short-circuit protection
Analogue input number	1
Analogue input type	Configurable current AI1 0...20 mA 250 Ohm Configurable voltage AI1 0...10 V 30 kOhm Configurable voltage AI1 0...5 V 30 kOhm
Discrete input number	4
Discrete input type	Programmable LI1...LI4 24 V 18...30 V
Discrete input logic	Negative logic (sink), > 16 V (state 0), < 10 V (state 1), input impedance 3.5 kOhm Positive logic (source), 0...< 5 V (state 0), > 11 V (state 1)
Sampling duration	10 ms for analogue input 20 ms, tolerance +/- 1 ms for logic input
Linearity error	+/- 0.3 % of maximum value for analogue input
Analogue output number	1
Analogue output type	AO1 software-configurable voltage: 0...10 V, impedance: 470 Ohm, resolution 8 bits AO1 software-configurable current: 0...20 mA, impedance: 800 Ohm, resolution 8 bits
Discrete output number	2
Discrete output type	Logic output LO+, LO- Protected relay output R1A, R1B, R1C 1 C/O

Minimum switching current	5 mA at 24 V DC for logic relay
Maximum switching current	2 A at 250 V AC on inductive load $\cos \phi = 0.4$ L/R = 7 ms for logic relay 2 A at 30 V DC on inductive load $\cos \phi = 0.4$ L/R = 7 ms for logic relay 3 A at 250 V AC on resistive load $\cos \phi = 1$ L/R = 0 ms for logic relay 4 A at 30 V DC on resistive load $\cos \phi = 1$ L/R = 0 ms for logic relay
Acceleration and deceleration ramps	S U Linear from 0...999.9 s
Braking to standstill	By DC injection, <30 s
Protection type	Line supply overvoltage Line supply undervoltage Overcurrent between output phases and earth Overheating protection Short-circuit between motor phases Against input phase loss in three-phase Thermal motor protection via the drive by continuous calculation of I^2t
Frequency resolution	Analog input: converter A/D, 10 bits Display unit: 0.1 Hz
Time constant	20 ms +/- 1 ms for reference change
Operating position	Vertical +/- 10 degree
Height	184 mm
Width	140 mm
Depth	151 mm
Net weight	1.8 kg

Environment

Electromagnetic compatibility	Electrical fast transient/burst immunity test - test level: level 4 conforming to IEC 61000-4-4 Electrostatic discharge immunity test - test level: level 3 conforming to IEC 61000-4-2 Immunity to conducted disturbances - test level: level 3 conforming to IEC 61000-4-6 Radiated radio-frequency electromagnetic field immunity test - test level: level 3 conforming to IEC 61000-4-3 Voltage dips and interruptions immunity test conforming to IEC 61000-4-11 Surge immunity test - test level: level 3 conforming to IEC 61000-4-5
Standards	IEC 61800-3 IEC 61800-5-1
IP degree of protection	IP20 without blanking plate on upper part IP41 top
Pollution degree	2 conforming to IEC 61800-5-1
Environmental characteristic	Dust pollution resistance class 3S2 conforming to IEC 60721-3-3 Chemical pollution resistance class 3C3 conforming to IEC 60721-3-3
Shock resistance	15 gn conforming to IEC 60068-2-27 for 11 ms
Relative humidity	5...95 % without condensation conforming to IEC 60068-2-3 5...95 % without dripping water conforming to IEC 60068-2-3
Ambient air temperature for storage	-25...70 °C
Ambient air temperature for operation	-10...55 °C without derating 55...60 °C protective cover from the top of the drive removed with current derating 2.2 % per °C
Operating altitude	<= 1000 m without derating

Packing Units

Unit Type of Package 1	PCE
Number of Units in Package 1	1

Package 1 Height	18.338 cm
Package 1 Width	18.862 cm
Package 1 Length	23.21 cm
Package 1 Weight	2.141 kg
Unit Type of Package 2	S04
Number of Units in Package 2	4
Package 2 Height	30.0 cm
Package 2 Width	40.0 cm
Package 2 Length	60.0 cm
Package 2 Weight	9.711 kg

Environmental Data

Schneider Electric aims to achieve Net Zero status by 2050 through supply chain partnerships, lower impact materials, and circularity via our ongoing “Use Better, Use Longer, Use Again” campaign to extend product lifetimes and recyclability.

[Environmental Data explained >](#)

[How we assess product sustainability >](#)

Environmental footprint

Carbon footprint (kg.eq.CO2 per CR, Total Life cycle) **8115**

Environmental Disclosure [Product Environmental Profile](#)

Use Better

Materials and Substances

Packaging made with recycled cardboard **Yes**

Packaging without single use plastic **Yes**

[EU RoHS Directive](#) **Pro-active compliance (Product out of EU RoHS legal scope)**

SCIP Number **5b939136-3ce6-4efd-8751-a5f6e107c9f2**

REACH Regulation [REACH Declaration](#)

Energy efficiency

Product contributes to saved and avoided emissions **Yes**

Use Again

Repack and remanufacture

Circularity Profile [End of Life Information](#)

Take-back **No**

Dimensions Drawings

Dimensions

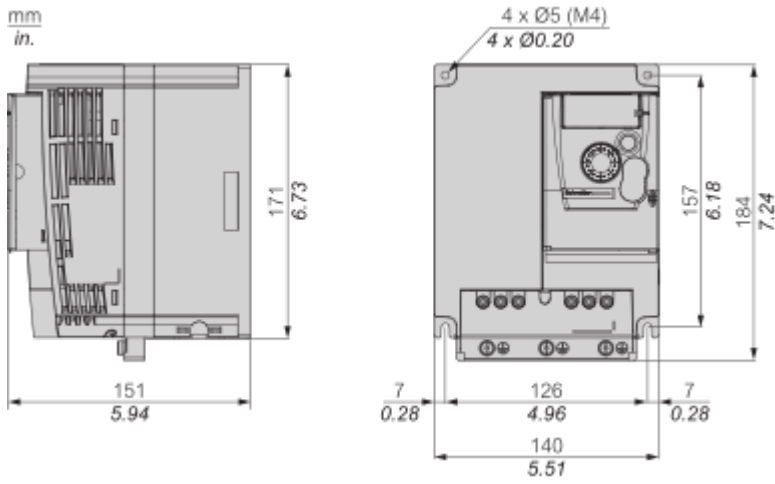

Mounting and Clearance

Mounting Recommendations

Clearance



Mounting Types

Mounting Type A

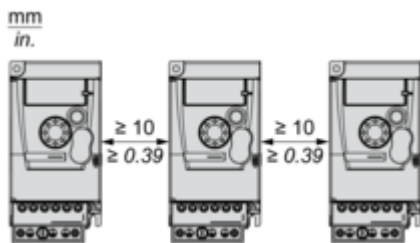

Mounting Type B

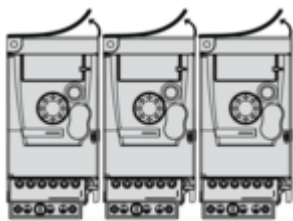

Remove the protective cover from the top of the drive.

Connections and Schema

Three-Phase Power Supply Wiring Diagram

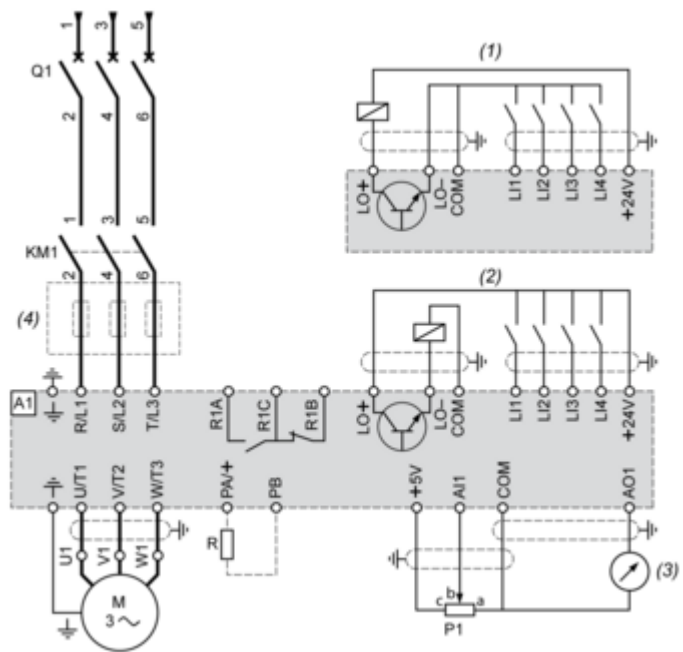

A1 : Drive

KM1 : Contactor (only if a control circuit is needed)

P1 : 2.2 kΩ reference potentiometer. This can be replaced by a 10 kΩ potentiometer (maximum).

Q1 : Circuit breaker

R : Braking resistor (optional)

(1) Negative logic (Sink)

(2) Positive logic (Source) (factory set configuration)

(3) 0...10 V or 0...20 mA

(4) Line choke three-phase (optional)

Technical Illustration

Dimensions

