

Product datasheet

Specifications



Motion control modules, Modicon Premium, 7.2 to 11.5W, 8ms to 10ms, for servomotors, limited and infinite axis

TSXCAY22

! Discontinued

! Discontinued on: 31 Dec 2018

! To be end-of-service on: 31 Dec 2026

Main

Range of product	Modicon Premium Automation platform
Product or component type	Motion control modules
Product specific application	For servo motors
Servo loop type	Proportional to overshoot compensation and gain switching 2 ms
Checks	Presence of voltage/sensor feedback counter input Consistency of commands Encoder coupling, servo drive present, emergency stop Proper execution of movement Sensor power supply Validity of parameters

Complementary

Speed profile path	Trapezoidal or parabolic
Resolution	≥ 0.5 position units per point ≤ 1000 position units per point
Length of axis	256...3200000 P
Acquisition speed	≤ 270000 points/mn ≥ 54000 points/mn
Acceleration time	8 ms...10 s
Operating mode	FOLLOWER OFF Direct drive mode Manual Automatic
Type of axis	Following axis dynamic ratio Limited axis Infinite axis
Function of module	Cut on the fly Servo drive offset correction
I/O modularity	2 axes
Input compatibility	Incremental encoder 10...30 V totem pole Incremental encoder 5 V DC RS422 With 2-wire/3-wire sensor (24 DC) auxiliary input Absolute encoder parallel output ABE7CPA11 Absolute encoder SSI output 12...25 bits
Clock frequency	200 kHz SSI absolute encoder
Incremental encoder frequency x1	500 kHz

Incremental encoder frequency x 4	1000 kHz in counting 250 kHz in input
Power dissipation in W	7.2...11.5 W
Input type	Current sink auxiliary input conforming to EN/IEC 1131 Type 2 Resistive servo drive control input conforming to EN/IEC 1131 Type 1 Resistive counter input
Input logic	Positive
Input voltage	24 V 8 mA auxiliary input 24 V 8 mA servo drive control input 5 V 18 mA counter input
Input voltage limits	<= 5.5 V counter input 19...30 V auxiliary input 19...30 V servo drive control input
Voltage state 1 guaranteed	>= 11 V for auxiliary input >= 11 V for servo drive control input >= 2.4 V for counter input
Current state 1 guaranteed	>= 3.5 mA (servo drive control input) >= 3.7 mA (counter input) >= 6 mA (auxiliary input)
Voltage state 0 guaranteed	<= 1.2 V for counter input <= 5 V for auxiliary input <= 5 V for servo drive control input
Current state 0 guaranteed	<= 1 mA (counter input) <= 1.5 mA (servo drive control input) <= 2 mA (auxiliary input)
Input impedance	270 Ohm for counter input 3000 Ohm for auxiliary input 3000 Ohm for servo drive control input
Number of outputs	2 reflex output static conforming to EN/IEC 61131 2 analogue output static 2 servo drive validation output relay
Analogue output range	+/- 10...24 V
Analogue output resolution	13 bits + sign
LSB value	1.25 mV for analogue output
Output voltage	24 V DC reflex output: 24 V DC servo drive validation output:
Output voltage limits	Reflex output: 19...30 V Servo drive validation output: 5...30 V
Nominal output current	0.5 A for reflex output
Maximum output current	1.5 mA analogue output 200 mA servo drive validation output 625 mA reflex output
Minimum load	1 mA 1 V
Maximum voltage drop	<1 V at state on for reflex output
Maximum leakage current	0.3 mA for reflex output
Switching time	< 5 ms for servo drive validation < 500 µs for reflex output
Output compatibility	Positive logic DC inputs (resistance <= 15 kOhm) for reflex
Short-circuit protection	Current limiter reflex output Thermal tripping reflex output
Output overload protection	Current limiter reflex output Thermal tripping reflex output
Output overvoltage protection	Zener diode between outputs and 24 DC reflex output

Reverse polarity protection	Reflex output: reverse diode on supply
Local signalling	1 LED (green) for module operating (RUN) 1 LED (red) for external fault (I/O) 1 LED (red) for internal fault, module failure (ERR) 2 LEDs (green) for axis diagnostics available
Electrical connection	1 connector HE-10 with 20 pins for aux inputs, reflex output, for external sensor and preactuator power supply 1 connector HE-10 with 20 pins for servo drive ctrl inputs + for ext power supply of servo drive inputs/outputs 1 connector SUB-D 9 for an analogue output (speed reference) 2 connectors SUB-D 15 for an incremental or absolute encoder
Current consumption	11...20 mA at 24 V DC on 10/30 V absolute encoder module 1100 mA at 5 V DC 15 mA at 24 V DC
Module format	Standard
Product weight	0.48 kg

Environment

Protective treatment	TC
Ambient air temperature for operation	0...60 °C
Ambient air temperature for storage	-25...70 °C
Relative humidity	5...95 % without condensation
Operating altitude	<= 2000 m

Packing Units

Unit Type of Package 1	PCE
Number of Units in Package 1	1
Package 1 Height	5.5 cm
Package 1 Width	18.0 cm
Package 1 Length	26.0 cm
Package 1 Weight	636.0 g

Contractual warranty

Warranty (in months)	18
-----------------------------	----



Environmental Data

Schneider Electric aims to achieve Net Zero status by 2050 through supply chain partnerships, lower impact materials, and circularity via our ongoing “Use Better, Use Longer, Use Again” campaign to extend product lifetimes and recyclability.

[Environmental Data explained >](#)

[How we assess product sustainability >](#)

Use Longer



Lifetime extension

Repair

No

Dimensions Drawings

Standard and Extendable Racks for Modules Mounting

Dimensions of Modules and Racks

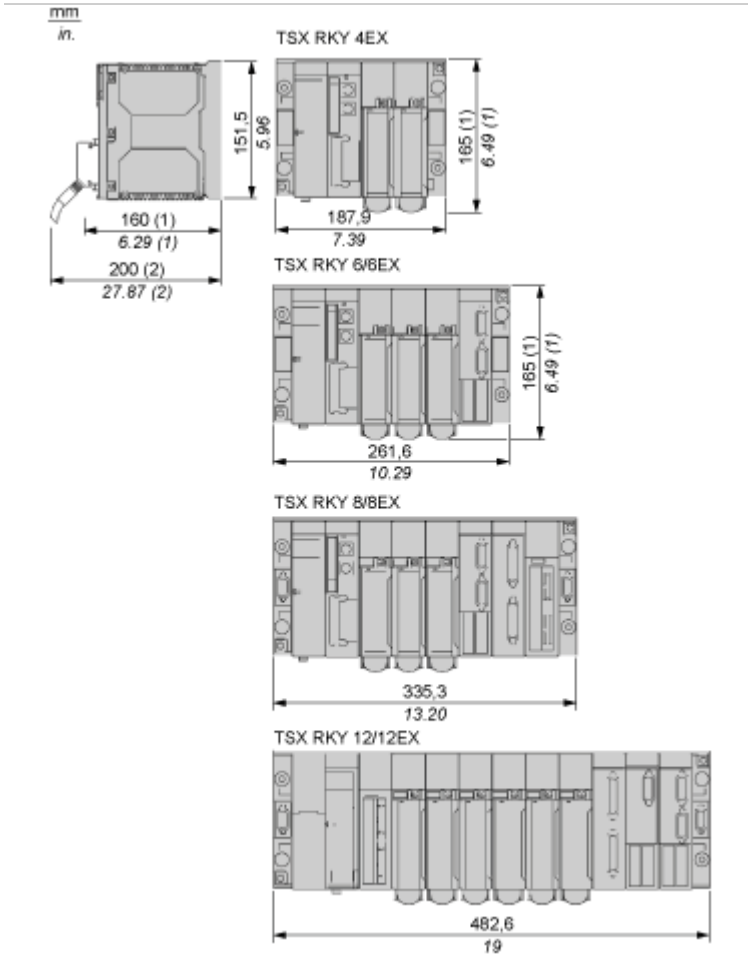

- (1) With screw terminal block modules.
- (2) Maximum depth for all types of modules and their associated connectors.

Connections and Schema

Connection of Speed Reference Signals

Connector Pinout

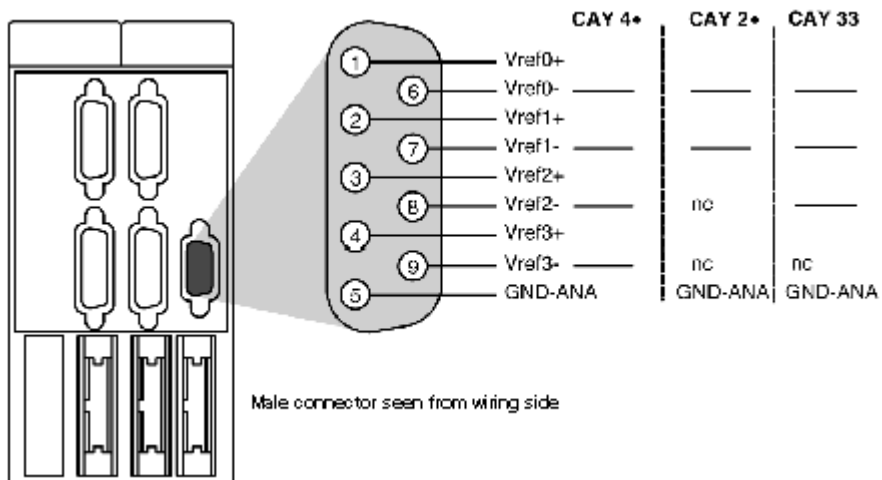

Connection of Counting Signals

Connectors Pinouts

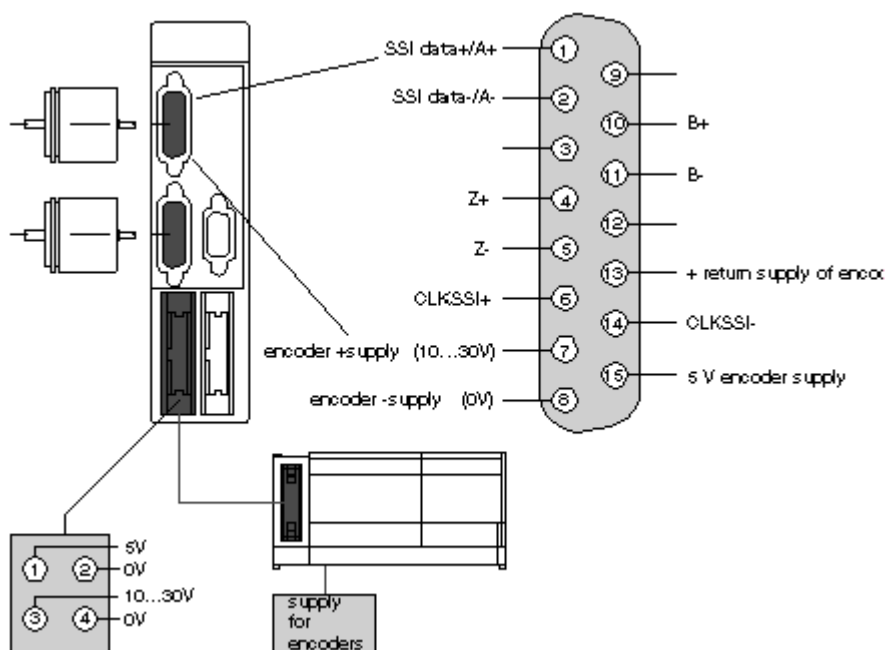

Element	Designation	Terminal
Incremental encoder	input A+	1
	input A-	2
	input Z+	4
	input Z-	5
	input B+	10
	input B-	11
	return supply of encoder	13
Absolute SSI encoder:	+ SSI Data	1
	- SSI data	2
	CLKSSI+	6
	CLKSSI-	14
5 V encoder power supply	+supply (5 V)	15
	- supply (0 V)	8
Encoder power supply (10-30 V)	+supply (10-30 V)	7
	- supply (0 V)	8

Connection of Sensors/Pre-actuators and Encoder Power Supply, without Variable Speed Controller

HE10 Connector Pinout

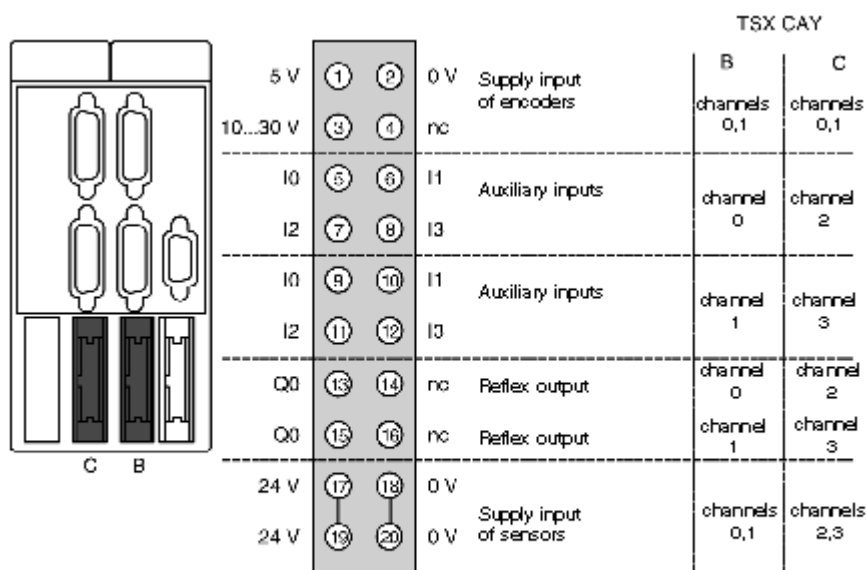

TSX CAY 2* module: Channels 0 and 1
 TSX CAY 4* module: Channels 0,1,2 and 3
 TSX CAY 33* module: Channels 0,1 and 2

The auxiliary inputs/outputs are allocated the following functions:

- I0 = cam reference point input,
- I1 =emergency stop input (stop if there is no current in the input),
- I2 = adjusting input,
- I3 = adjustment input,
- Q0 = reflex output (static output),
- 0 V = shared auxiliary inputs and reflex outputs.

Connection of the Variable Speed Controller Signals

Connector Pinout

The axis command modules implement basic management of the signals necessary for correct operation of the variable speed controllers. There is only one connector, regardless of the number of axis command module channels.

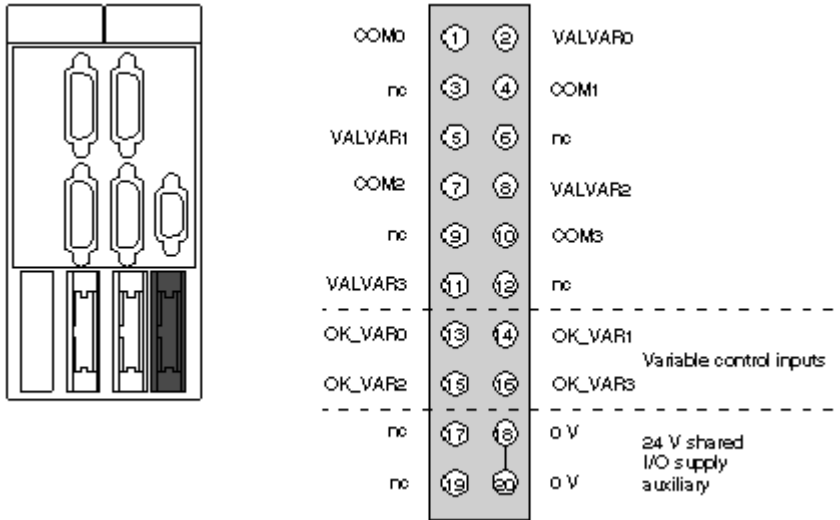

COMx – VALVARx: potential free contact to validate variable speed controller

OK_VARx: variable speed controller input check

24 V – 0 V sensor power supply

NOTE: Each channel uses a potential free closing contact.